



■ Some of the photos may include optional equipment.

We build a better future

15D/18D/20DA-7E

FORKLIFT TRUCKS Environmental - Friendly



FORKLIFT Excellent Model

15D/18D/20DA -7E

New criterion of Forklift Trucks

Hyundai introduces with its 7-series a new line of diesel forklift trucks. Excellent power and performance improves your business profitability.

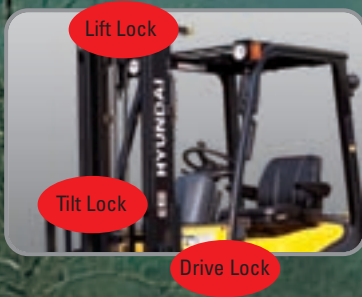

OPSS (Operator Presence Sensing System)

Most tilting, lifting and lowering operation is not possible when the operator is not seated in normal position. (Option)

15D/18D/20DA -7E



■ Some of the photos may include optional equipment.

High Power & Performance

Powerful Engine

KUBOTA V2203 Engine

The Kubota V2203 engine ensures an incomparable performance and durability; with its market approved quality, this engine gives an additional value to the machine. With its power of 30.8 kW, it will fit for any work, even with special attachments that require extensive power.

30.8 kW / 2,300 rpm



State-of-the-art hydraulic system

The latest designed, large-capacity hydraulic system including a low-noise control valve shortens reaction time during operation and improves both efficiency and durability.

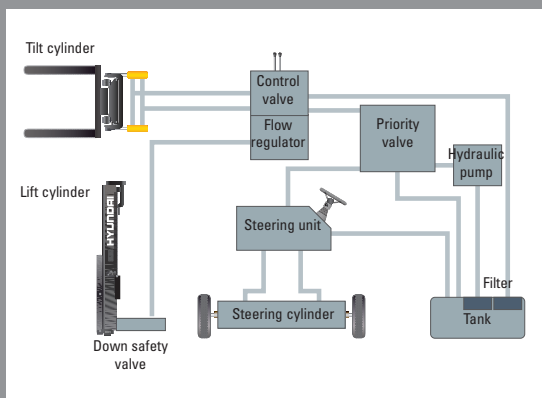

The new master on the job-site!

Smooth running, efficient and ergonomically designed, 15D/18D/20DA-7E series are made to meet your needs.



Fast and stable performance

Being able to quickly raise and lower the mast, as well as tilt it forward and backward, the truck provides you the best operational conditions during loading/unloading jobs. With a loaded truck, mast lowering speed is carefully controlled by a down control valve to ensure full safety on the job.

15D/18D/20DA -7E



■ Some of the photos may include optional equipment.

Faster Travel Speed & Grade-ability

The powerful high-output engine provides greater acceleration, better grade-ability and faster travel speed on any tough terrain or slope.

Grade-ability (Loaded)

15D-7E	21.1°
18D-7E	19.1°
20DA-7E	17.9°

Travel speed (Unloaded)

15D-7E	19.3 km/h
18D-7E	19.3 km/h
20DA-7E	19.3 km/h



Increased mast tilting angle

Utilizing the mast tilting angle of 6 degrees forward and 10 degrees backward gives the operator a safe and rapid platform for loading and unloading jobs.



Wet Disc Brake System

The adoption of wet disc type brakes improves the brake performance and makes your service intervals longer. Enclosed brakes are protected against dust and water.



Full hydrostatic power steering

A hydraulic steering system always guarantees smooth and flexible steering, preventing overrun and steering wheel kick-back.



Key-locking fuel cap

To increase security and down time on the job, a larger fuel tank with a locking fuel cap is installed.

Comfortable Operation



Adjustable steering wheel

The steering wheel can be adjusted by a lever on the left-hand side to improve operators comfort.



Easy and safe shift lever

A single lever on the left side of the steering column gives the operator fast, easy control of direction.



Multi-functional lever

A Multi-functional lever gives easy access to lights and horn.



Quick Response of Operating Control Levers

Only minimal operator's effort is required for precise, safe and productive control.



Some of the photos may include optional equipment.



Ergonomically positioned pedals

Based on human engineering, the accelerator, brake and inching pedals are optimally positioned for operator's convenience.



Cup holder & console box

Additional storage spaces are located inside the operating space.

Ergonomic based space design

A design based on human engineering relieves fatigue and increases operator's efficiency.



New high visibility for safe operation

The operator is able to work with increased safety and accuracy due to a wider view mast.

Operator friendly gauges and water-resistant monitor panel



- | | |
|---|---------------------------|
| ① Parking brake lamp | ⑨ Water separator lamp |
| ② Directional indicators | ⑩ Pre-heater indicator |
| ③ Fuel warning lamp | ⑪ Water temperature gauge |
| ④ Engine oil warning lamp | ⑫ Fuel gauge |
| ⑤ Transmission oil temperature warning lamp | ⑬ Hour meter |
| ⑥ Battery charging warning lamp | ⑭ Engine check lamp |
| ⑦ Air filter warning light | ⑮ Seat belt warning |
| ⑧ Working light indicator | ⑯ OPSS warning |

Easily adjustable suspension seat

An attractive and adjustable seat, based on a human engineering design, provides great comfort, safety and durability.



The latest anti-vibration and shock absorbing system

The anti-vibration rubber is installed between the guard and truck frame to reduce the source of vibration and noise while driving. This will not only reduce operator's fatigue but will also increase safety.



Endurance & Safety

Strong overhead guard

The safety overhead guard meets EEC and ANSI regulations and protects the operator during hazardous jobs.



Parking Brake

Toggle type parking brake requires less effort from the operator to set.



High Durable Split Type Drive Axle

The power-shift transmission provides you with fast but quiet travel speed under all heavy load conditions. So boosting your work efficiency.

Safety Through High Durability!

Safety and durability are priorities in the design of the equipment.



Large footboard & Handle

Wide "open" step offers convenience and safety when entering and exiting truck.

15D/18D/20DA -7E



■ Some of the photos may include optional equipment.

Heavy duty single unit frame

Heavy duty single unit type frame, designed on the basis of accurate structural analysis, guaranteeing durability and safety.

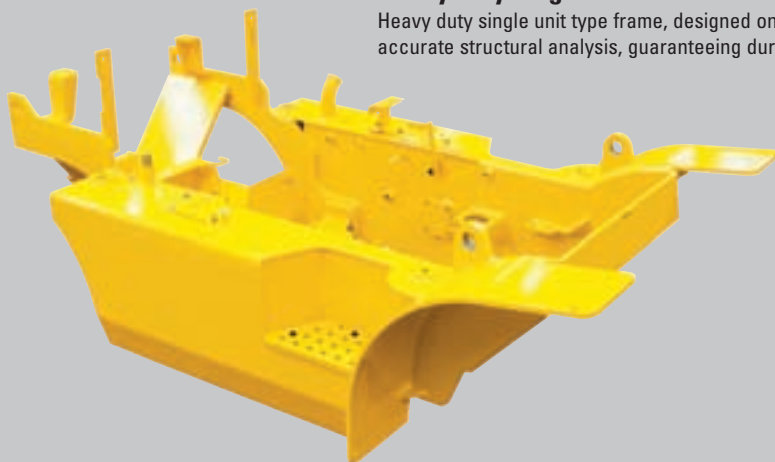

Easy Access to Electrical Components

Under the dash board the electric parts are centralized to improve maintenance.



Expansion bellows

The expansion bellows absorbs vibrations and reduces noise generated from the exhaust gas system to extend the life span.



Bright, protected headlights

Bright, protected headlights are positioned for exceptional visibility in dark environments.

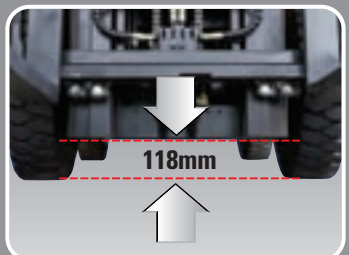

Ground clearance

The engine and transmission are assembled horizontally and positioned high in the frame to protect expensive components during operation on rugged surfaces.

Durability & Easy Maintenance



Electrical Monitored Air Filter

An air cleaner sensor alerts the operator of a restricted air filter so allowing replacement before potential engine damage occur.



Easy Maintenance oil check

The T/M oil level can be checked easily without any disassembly.



Brake fluid reservoir

Highly visible and accessible reservoir makes daily inspections a quick and easy job.

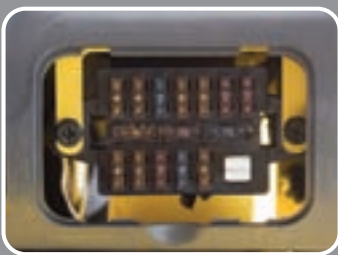

An accessible, compact fuse box for easy inspection



Centralized design for easy service!

An ideal arrangement of components ensures easy access and convenience during maintenance.



Easy Change of Air Cleaner

The air filter is readily accessible for cleaning or replacement. (7inch Cyclone Type)



Low weight Side Cover



Rotating battery installation

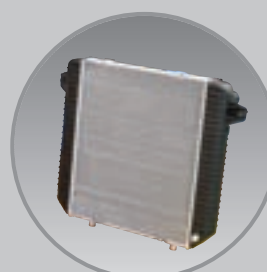

Aluminum radiator with superb protection against heat



Quick and Easy Engine Oil Check

15D/18D/20DA-7E

Mast Specifications

Mast Type	Overall Height (lowered)	Maximum Fork Height			Free Lift				Tilt Angle (deg)		Load Capacity w / o Side Shift (500 mm) LC Single Tire			Load Capacity w / Side Shift (500 mm) LC Single Tire			Truck Weight Unloaded Single Tire		
					With backrest		Without backrest				15D-7E	18D-7E	20DA-7E	15D-7E	18D-7E	20DA-7E	15D-7E	18D-7E	20DA-7E
		15D/18D/20DA-7E	15/18D-7E	20DA-7E	15D/18D-7E	20DA-7E	15D/18D-7E	20DA-7E											
		mm	mm	mm	mm	mm	mm	mm	mm	Fwd	Bwd	kg	kg	kg	kg	kg	kg	kg	kg
2-Stage Limited Free Lift	V250	1,755	2,525	2,530	145	150	145	150	6	10	1,500	1,750	2,000	1,400	1,650	1,890	2,798	2,916	3,063
	V270	1,855	2,725	2,730	145	150	145	150	6	10	1,500	1,750	2,000	1,400	1,650	1,890	2,812	2,930	3,076
	V300	2,005	3,025	3,030	145	150	145	150	6	10	1,500	1,750	2,000	1,400	1,650	1,890	2,832	2,950	3,096
	*V330	2,155	3,325	3,330	145	150	145	150	6	10	1,500	1,750	2,000	1,400	1,650	1,890	2,852	2,970	3,116
	V350	2,255	3,525	3,530	145	150	145	150	6	10	1,500	1,750	2,000	1,400	1,650	1,890	2,865	2,983	3,130
	V370	2,355	3,725	3,730	145	150	145	150	6	10	1,500	1,750	1,950	1,400	1,650	1,850	2,879	2,997	3,143
	V400	2,505	4,025	4,030	145	150	145	150	6	10	1,475	1,700	1,550	1,390	1,600	1,470	2,903	3,021	3,168
	V450	2,855	4,525	4,530	145	150	145	150	6	6	1,425	1,625	1,500	1,340	1,535	1,420	2,970	3,088	3,235
	V500	3,105	5,025	5,030	145	150	145	150	6	6	1,350	1,450	1,050	1,270	1,370	980	3,003	3,121	3,268
	V550	3,355	5,525	5,530	145	150	145	150	6	5	1,050	1,000	825	970	930	760	3,037	3,142	3,289
3-Stage Full Free Lift	TF370	1,805	3,735	3,740	798	803	1,299	1,300	6	6	1,500	1,725	1,900	1,400	1,650	1,810	2,895	3,065	3,221
	TF400	1,905	4,035	4,040	898	903	1,399	1,400	6	6	1,475	1,675	1,850	1,400	1,610	1,770	2,914	3,084	3,240
	TF430	2,005	4,335	4,340	998	1,003	1,499	1,500	6	6	1,425	1,625	1,800	1,365	1,560	1,720	2,933	3,103	3,259
	TF450	2,105	4,535	4,540	1,098	1,103	1,599	1,600	6	6	1,400	1,600	1,700	1,340	1,535	1,620	2,953	3,123	3,279
	TF470	2,155	4,735	4,740	1,148	1,153	1,649	1,650	6	6	1,375	1,475	1,400	1,315	1,415	1,350	2,964	3,134	3,290
	TF500	2,255	5,035	5,040	1,248	1,253	1,749	1,750	6	6	1,350	1,425	1,050	1,290	1,370	1,020	2,984	3,154	3,310
	TF550	2,455	5,535	5,540	1,448	1,453	1,949	1,950	6	5	1,125	1,125	800	1,075	1,085	780	3,022	3,192	3,348
	TF600	2,655	6,035	6,040	1,648	1,653	2,149	2,150	6	5	775	775	500	750	755	490	3,094	3,264	3,420
	TF650	2,855	6,535	6,540	1,848	1,853	2,349	2,350	3	3	525	525	450	510	510	440	3,138	3,308	3,464
	TF700	3,055	7,035	7,040	2,048	2,053	2,549	2,550	3	3	375	350	325	365	340	315	3,174	3,344	3,500

*Standard

Load Capacity

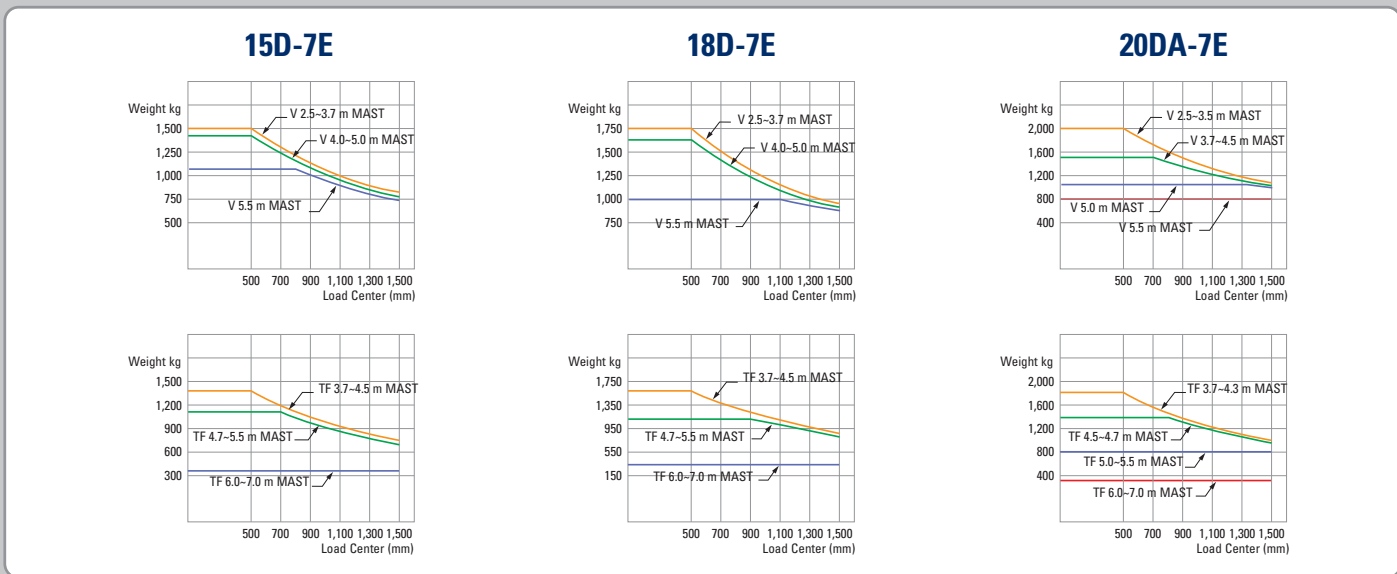

Dimensions

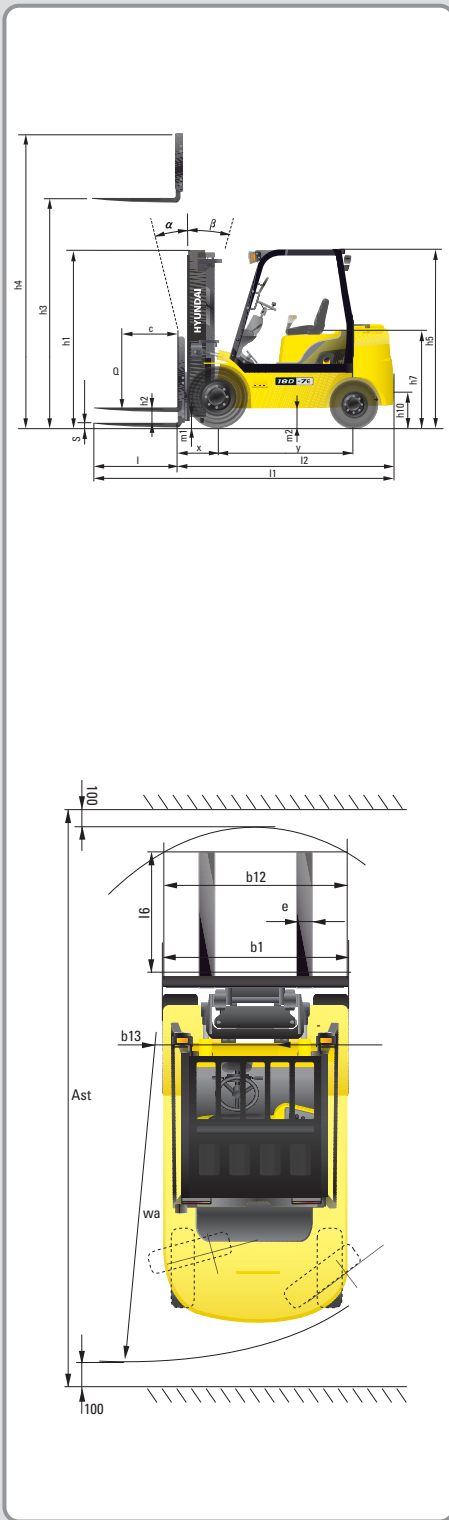

Specifications

Identification			
1.1	Manufacturer	Hyundai	Hyundai
1.2	Type	15D-7E	18D-7E
1.3	Drive: electric (battery or mains), diesel, petrol, fuel gas, manual	DIESEL	DIESEL
1.4	Type of operation: hand, pedestrian, standing, seated, order-picker	seated	seated
1.5	Load capacity (standard)	kg 1,500	1,750
1.6	Load center distance	c mm 500	500
1.8	Load distance, center of drive axle to forks	x mm 394	394
1.9	Wheelbase	y mm 1,422	1,422
Weights			
2.1	Service weight	kg 2,850	3,020
2.2	Axle loading, loaded front / rear	kg 3,754 / 596	4,116 / 654
2.3	Axle loading, unloaded front / rear	kg 1,305 / 1,546	1,256 / 1,763
Wheels, Chassis			
3.1	Tires: solid rubber, superelastic, pneumatic, polyurethane	pneumatic	pneumatic
3.2	Tires size, front (Φ x width)	6.50-10-12PR	6.50-10-12PR
3.3	Tires size, rear (Φ x width)	5.00-8-10PR	5.00-8-10PR
3.5	Wheels, number front / rear (x = driven wheels)	2x / 2	2x / 2
3.6	Track width, front	mm 889	889
3.7	Track width, rear	mm 914	914
Basic Dimensions			
4.1	Mast / fork carriage tilt forward / backward (α/β)	degrees 6 / 10	6 / 10
4.2	Lowered mast height	h1 (mm) 2,159	2,159
4.3	Free lift	h2 (mm) 145	150
4.4	Lift height	h3 (mm) 3,327	3,327
4.5	Extended mast height	h4 (mm) 4,343	4,343
4.7	Overhead load guard (cab) height	h5 (mm) 2,108	2,108
4.8	Seat height / standing height	h7 (mm) 1,049	1,049
4.12	Coupling height	h10 (mm) 262	257
4.19	Overall length	l1 (mm) 3,124	3,200
4.20	Length to face of forks	l2 (mm) 2,235	2,311
4.21	Overall width	b1 (mm) 1,067	1,067
4.22	Fork dimensions (hook type)	S x E x L (mm) 900 x 100 x 35	900 x 100 x 40
4.23	Fork carriage ISO 2328, class / type A, B	2A	3A
4.24	Fork carriage width	b12 (mm) 980	980
4.31	Ground clearance, loaded, under mast	m1 (mm) 119	119
4.32	Ground clearance, centre of wheelbase	m2 (mm) 145	145
4.33	Aisle width for pallets 1,000 x 1,200 crossways (L x W)	Ast (mm) 3,579	3,650
4.34	Aisle width for pallets 800 x 1,200 lengthways (W x L)	Ast (mm) 3,780	3,848
4.35	Turning radius	Wa (mm) 1,984	2,050
4.36	Smallest pivot point distance	b13 (mm) 587	587
Performance Data			
5.1	Travel speed, unloaded	km/h 19.5	19.5
5.2	Lift speed, loaded / unloaded	mm/sec 620 / 650	600 / 650
5.3	Lowering speed, loaded / unloaded	mm/sec 498 / 452	498 / 452
5.5	Drawbar pull, loaded	kg 1,669	1,692
5.7	Gradient performance, loaded / unloaded	% 31.5 / 24.3	28.2 / 22.0
5.9	Acceleration time, loaded / unloaded (10 m)	sec NA	NA
5.10	Service brake	FOOT	FOOT
Engine			
6.1	Engine manufacturer / type	KUBOTA V2203	KUBOTA V2203
6.2	Engine power acc. to ISO 1585	kW 30.8	30.8
6.3	Rated speed	1/min 2,400	2,400
6.4	No. of cylinder / cubic capacity	anz/cm ³ 4 / 2,197	4 / 2,197
6.5	Fuel consumption acc. To VDI cycle	liter/h NA	2.86
Other Details			
8.1	Type of drive control	power shift	power shift
8.2	Operating pressure (System / attach) bar	bar 195 / 155	195 / 155
8.3	Hydraulic oil volume	liter 30	30
8.4	Sound level at driver's ear according to (DIN 12 053)	dB (A) 80	80

1) with DZ mast + 25mm; with integrated sideshift x = 375 mm (with DZ mast + 25 mm); with hook-on sideshift x = 410.5 mm (with DZ mast + 25 mm)

Contact your Hyundai dealer for more information. The machine shown may vary according to International standards.
All US measurement rounded off to nearest pounds or inches. Materials and specifications are subject to change without notice.



Head Office(Sales Office)
1 JEONHA-DONG, DONG-GU, ULSAN, KOREA Tel (82) (52) 202-7970, 7729 Fax (82) (52) 202-7979, 7720

U.S. Operation : Hyundai Construction Equipment U.S.A., Inc.
955 ESTES AVENUE, ELK GROVE VILLAGE IL., 60007 Tel (1) 847-437-3333 Fax (1) 847-437-3574

European Operation : Hyundai Heavy Industries Europe N.V.
VOSSENDAAL 11, 2440 GEEL, BELGIUM Tel (32) 14-562200 Fax (32) 14-593405-06

India Operation : Hyundai Construction Equipment India Private Limited
303, 3rd Floor, Siddhivinayak Aurum, 33/1/1/2 Vadgaon Sheri,
Viman Nagar, Pune 411 014 India Tel 91-20-4003-8160 Fax 91-20-4003-8163

PLEASE CONTACT

www.hyundai.eu

EN - 2008. 04 Rev 0